



Aperion Audio
Bravus Analog Subwoofer
Model 8A
Owner's Guide

IMPORTANT SAFETY INSTRUCTIONS



CAUTION
RISK OF ELECTRIC SHOCK
DO NOT OPEN

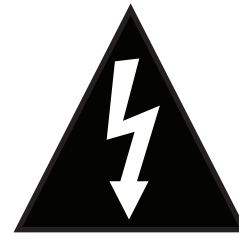

Caution

To reduce the risk of electric shock, do not remove the amplifier. No user-serviceable parts are inside. Refer servicing to qualified service personnel.

The exclamation point symbol is intended to alert user to the presence of important operating and maintenance (servicing) instructions in the literature accompanying the subwoofer.

The lightning flash with arrowhead symbol is intended to alert the user to the presence of uninsulated “dangerous voltage” within the product’s enclosure that may be of sufficient magnitude to constitute a risk of electric shock to persons.

1. Read Instructions - All safety and operating instructions should be read before the product is operated.
2. Retain Instructions - The safety and operating instructions should be retained for future reference.
3. Heed Warnings - All warnings on the product and in the operating instructions should be adhered to.
4. Water and Moisture - The product should not be used near water - for example, near a bathtub, wash-bowl, kitchen sink, laundry tub, in a wet basement, near a swimming pool or the like.
5. Ventilation - The product should be situated so that its location or position does not interfere with its proper ventilation or the movement of its parts.
6. Heat - The product should be situated away from heat sources such as radiators, heat registers, stoves, or other products that produce heat.
7. Power Sources - The product should be connected to a power supply only of the type described in the operating instructions or as marked on the product.
8. Power-Cord Protection - Power-supply cords should be routed so that they are not likely to be walked on or pinched by items placed upon or against them, paying particular attention to cords at plugs, convenience receptacles, and the point at which they exit from the product.
9. Cleaning - The product should be cleaned only as recommended by the manufacturer. See pg. 9.
10. Object and Liquid Entry - Care should be taken so that objects do not fall and liquids are not spilled on to the enclosure.
11. Servicing - The user should not attempt to service the product beyond what is described in the operating instructions. All other servicing should be referred to qualified service personnel.
12. Lightning - For added protection for the product during a lightning storm or when it is left unattended and unused for long periods of time, unplug it from the wall outlet.
13. Overloading - Do not overload wall outlets, extension cords or integral convenience receptacles as this can result in a risk of fire or electric shock.

Table of Contents

Congratulations	3
Before You Begin	3
Product Features	3
Installing Subwoofer Feet	4
Placement	4
Connecting Your Subwoofer	5
Subwoofer Controls & Configuration	6
Receiver Setup	7
Specifications	8
Warranty	8
Contact Us	8
Legal Notice	9
Notes	10

Congratulations

You've made an inspired decision. We created this subwoofer with the intention to give you the greatest sub-bass experience possible, and we think we've succeeded.

Careful! This powerful subwoofer packs enough punch to get you some serious complaints from your home owner's association. To mitigate this possibility, be sure to extend an invitation to your neighbors to enjoy your new subwoofer with you.

Before You Begin

Please confirm that the following accessories have been included.

- AC Power Cord
- 4 Metal Carpet Spikes
- 4 Metal Footers
- 4 Rubber Feet

If any of the above items are missing from your shipment, please contact Aperion Audio immediately toll free. 888.880.8992.

Before rockin' your new Aperion subwoofer, we also have the following precautions and suggestions:

- Due to the weight of our subwoofers, we recommend that the unboxing, moving, and positioning of the unit be done by two people to avoid injury or damage to the floor or unit.
- Do not tap on the aluminium driver or touch it while the subwoofer is operating. This can cause unsightly dents in the cone.
- Do not plug the power cord into your subwoofer until all other connections are made.
- Be sure to check the specifications and warnings listed about your receiver and other electronic gear.
- Do not operate the subwoofer until the metal or rubber feet have been installed. Doing so may mar the subwoofer's finish or damage your floor.
- The carpet spikes may cause damage to surfaces such as wood floors and tight weave rugs. If you're going to use the subwoofer on such a surface, use the supplied metal footers under the carpet spikes or the rubber feet to protect the floor. You are responsible for determining when use of these disks is required.
- Be sure to make all connections securely. Failing to do so may result in noise, poor performance, or damage to your equipment.
- Bundling subwoofer or speaker cable with a power cord can produce unwanted hum in your system. If the subwoofer cable must cross a power cord, try to cross the cables at a 90 degree angle.

Product Features

Your new Aperion Bravus subwoofer is packed with features. They include:

- Custom high-excursion aluminium driver for equal parts precision and low bass extension.
- Powerful 100 watt analog power amplifier for room rumbling performance.
- Internally braced HDF cabinet to ensure rock-solid performance without resonance.
- Detachable power cord.
- High level inputs for older electronics without line level output.
- Line level inputs to connect with modern electronic devices.
- Leveling floor spikes and footers to isolate the subwoofer and improve performance.

Product Support

Setting up a subwoofer can seem like a daunting task but it becomes simple when you plan it out and take your time. As always, lifetime technical support is provided with your system purchase. If you have any problems, call us at 888.880.8992. We also have technical support available on our website. Visit www.aperionaudio.com and search our knowledge base to find answers to common questions or use our forum as a resource to help you set-up and optimize your system.

If this information doesn't solve your problems or if you have additional questions, you can send email to: technicalsupport@aperionaudio.com, or visit our website and log on to live chat for instant help (M-F 8:00AM - 5:00PM, Pacific Time).

Specifications

Bravus 8A

Amp Power: 100W
Freq response: +3dB: 33 to 180 Hz
Freq response :+6dB: 30 to 180 Hz
Woofer: Single 8" high-excursion aluminum cone
Driver configuration: Single 8", down firing
Enclosure: Ported and internally braced, 3/4" HDF
Dimensions: 16.7" H x 13.5" W x 13.5" D (w/ feet)
Weight: 36 lbs.

Express Limited Warranty

Aperion Audio provides a **transferable ten (10) year limited warranty on our speakers**; a **transferable three (3) year limited warranty on our subwoofer amplifiers**; and a **non-transferable lifetime limited warranty on our cables**. No other warranty, implied or otherwise, is created or honored by Aperion Audio. These warranties cover all defects in material and workmanship with the following specific exceptions:

- Damage caused by improper installation or adjustment
- Damage caused by accident, unreasonable use, or neglect
- Damage caused by an act of God
- Damage from failure to follow instructions contained in the Owner's Manual
- Damage from repairs performed by someone not authorized by Aperion Audio
- Any unit on which the serial number has been effaced, modified, or removed
- Damage occurring during shipment, other than that arranged by Aperion Audio
- Units which have been altered or modified in design, appearance or construction

This warranty covers only the actual defects within the products themselves. IT DOES NOT cover costs of installation in (or removal from) a fixed installation, or normal set-up, claims based on any misrepresentation by the seller, or performance variations resulting from installation related circumstances such as signal quality, AC power or incompatibilities with other system components.

During the warranty period, Aperion Audio will, at its option, either repair the defect, or replace the defective product, or the defective parts, or components thereof with the then current product/component in use by Aperion Audio, at no charge to the owner for parts and labor covered by this warranty. If necessary repairs are not covered by this warranty, or if a unit is examined which is not in need of repair, you will be charged for the repairs and/or the examination.

If non-warranted repairs are needed, we will notify you of the estimated cost and ask for your authorization to perform said repairs. You must pay shipping charges incurred in getting your product to Aperion Audio. We will pay the return shipping charges if the repairs are covered by the warranty. Please save the original shipping cartons, as the unit MUST be returned in the original carton and packing. (Replacement cartons are available at a modest charge.)

Contact Us

If you have any questions, comments, or concerns, please don't hesitate to contact us.

www.aperionaudio.com
customerservice@aperionaudio.com
sales@aperionaudio.com

1.888.880.8992
18151 SW Boones Ferry Road
Portland, OR. 97224

Connecting Your Subwoofer

If your receiver has a subwoofer output: (Most modern receivers do)

1. Run a dedicated RCA type subwoofer cable from the receiver's subwoofer output to the subwoofer input labeled LFE. It is best to use a shielded cable for your subwoofer so other pesky signals don't worm their way into your precious bass.
2. If your subwoofer cable has to cross the power cable for another electronic device, have it cross at a 90-degree angle.
3. Plug the power cable into the back of your subwoofer and into a wall outlet or power strip. DO NOT plug it into the back of your receiver or preamp.

Note: Most subwoofers have both left & right inputs. Since the sub signal is mono, it doesn't matter which one you use. Some people will buy a "Y adapter" or "splitter" so that a single cable can feed both subwoofer inputs. There's no harm in doing this, the reason subwoofers have L & R inputs is so that if you have a stereo pre-amplifier, you can use both "pre-outs" to the subwoofer without losing any bass.

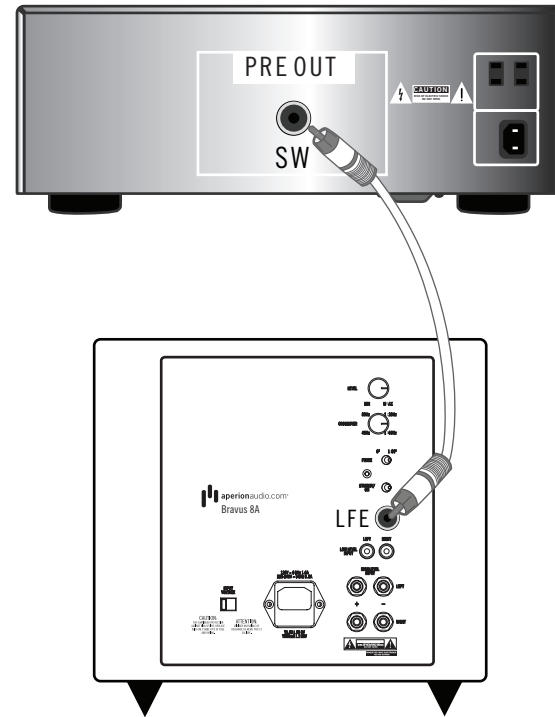

Subwoofer Controls & Configuration

Subwoofer Controls

In addition to the low-level inputs and outputs on the rear of your subwoofer, you will see two round knobs and two switches. The first knob, labeled "level" controls the subwoofer's volume. The second knob, "crossover" sets the crossover frequency, which is the frequency point where the subwoofer takes over from your other speakers to produce the bass you hear.

The power switch has two settings - on and off. When the switch is set in the "on" setting, the power lamp will be illuminated green. When set to the "off" position, the power lamp will turn off. The "phase" switch reverses the subwoofer's polarity. If the distance from the sub to the listener is significantly different than the front and center speakers (>3'), try using the phase reverse switch to see if it improves the bass response.

The 8A has a switchable voltage control. Please be sure to select 120V for use in the USA.

Subwoofer Configuration

After you're all hooked up, it's time to get rockin'. To get you started, our recommendations for initial settings are listed at the right.

Personal tastes vary, so we strongly recommend that you play with the settings. In addition to being fun, this helps you understand your subwoofer, while giving you a custom configuration for your listening tastes and your room.

As always, if you need any help, please feel free to give us a call at 1.888.880.8992 and one of our Home Theater Gurus will be happy to answer any questions you have or help you get room-shaking bass out of your subwoofer.

Recommended Initial Settings for the Bravus 8A

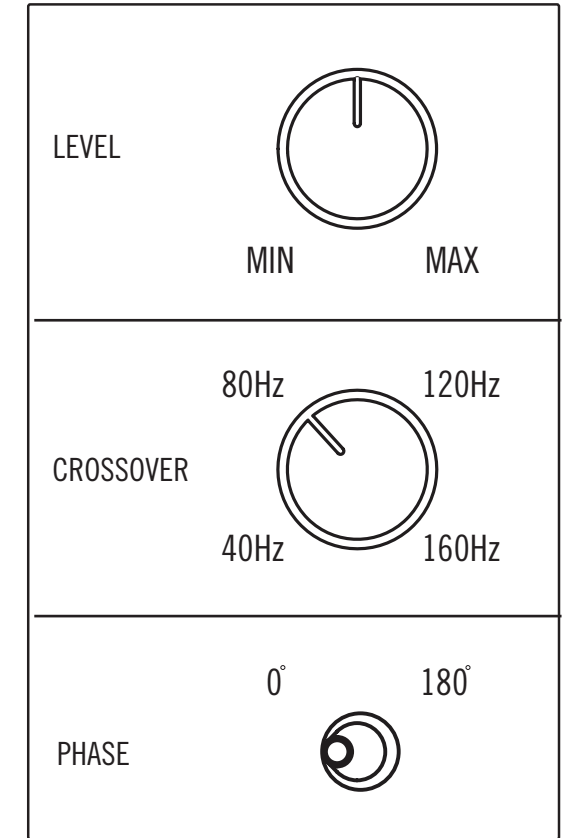

Phase: 0°
Crossover: 60-100 Hz
Level: 1/3 to 1/2 Power
Power: On

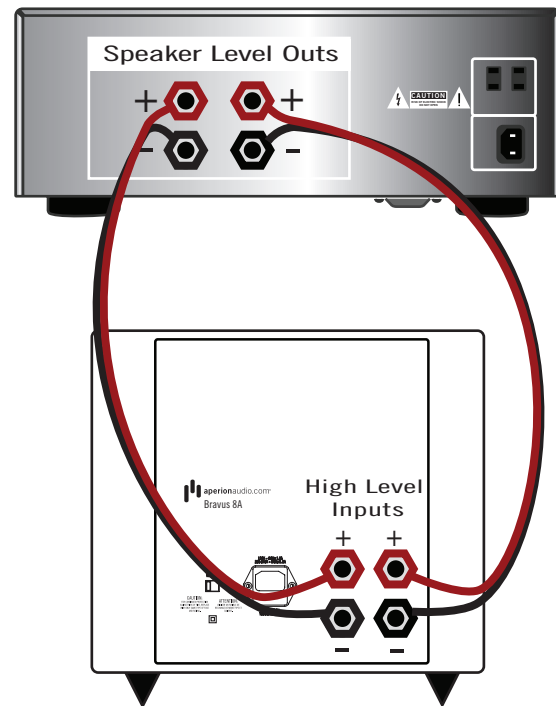

If your receiver DOES NOT have a subwoofer output:

1. Run speaker wires from your receiver (or your front left & right speakers) to the subwoofer's high-level inputs.
2. Since speaker wire is typically unshielded, it's best to steer clear of household wiring. If it does need to cross the power cable for another electronic device, have it cross at a 90-degree angle. If your subwoofer emits a buzz or a hum, this may be the culprit.
3. Plug the power cable into the back of your subwoofer and into a wall outlet or power strip. DO NOT plug it into the back of your receiver or preamp.

Receiver Setup

Receiver Setup

Setting up your subwoofer through your receiver only requires a few simple steps. You may have a receiver that has an auto calibration microphone, and while these are convenient, they are not always accurate. For best results, we recommend accessing the setup menu of your receiver and manually setting up the speakers. Most modern receivers use an On Screen Display setup menu (OSD) that make setup a breeze.

1. In your receiver's setup menu, go to "Speaker Setup" or "Speaker Configuration". Set the subwoofer value to "Yes" if your front speakers are "Small". If your front speakers are "Large" set the subwoofer value to "LFE + Main" (sometimes called Plus or Double Bass).

Note: Some receivers automatically turn off the subwoofer output when the front speakers are set to "Large" in the speaker setup menu. So be sure that you override this by completing setup number 1 above.

2. In the crossover menu, confirm that the crossover point of your front speakers matches the crossover point of your sub (e.g. - if your front speakers are crossed-over at 100Hz, your sub should be crossed-over at 100Hz). The manufacturer should list a recommended crossover point for of your speakers. Here are some of the recommended crossover points for Aperion Audio speakers.

Speaker*	Crossover Setting
4 Series Bookshelf	100Hz
5 Series Bookshelf	80 - 100Hz
6 Series Bookshelf	60 - 100Hz
4 Series Tower	80 - 100Hz
5 Series Tower	60 - 100Hz
6 Series Tower	40 - 100Hz

*If your Aperion speakers are not listed here, please check our website for crossover recommendations. www.aperionaudio.com

Important: Frequencies above 80Hz start becoming directional - meaning your ear can locate where they are coming from. So if your subwoofer is crossed-over above 80Hz, try to position it as close to your television as possible.

Note: Aperion Audio Bravus Subwoofers have an internal crossover. If you would like to use the subwoofer's internal crossover instead of your receiver's, you can defeat your receiver's crossover by turning it up to its maximum.

3. Next, navigate to the speaker distance menu. Here, simply measure the distance between your listening position and your sub and enter the value into the menu.

4. Finally, the subwoofer's volume level must be adjusted in the channel level menu. Of course, your subwoofer's volume will most frequently be changed using the level knob on the rear of the subwoofer. Calibrating your subwoofer's volume in the receiver setup menu simply alters the strength of the signal sent to your subwoofer from your receiver. Thus, it is not necessary to dial your subwoofer volume perfectly in the channel level menu.

To make a long story short, set the subwoofer level at zero in the channel level menu. All other adjustments to the subwoofer volume should be made with the controls on the rear of the subwoofer.

Note: Often times a receiver's auto setup tool will set the subwoofer volume to +12 or -12. In fact, if your subwoofer level is set to -12 in your receiver, it might be too low for the auto on function of your sub to detect. We think zero is a sensible place to start.

Installing Subwoofer Feet

Installing Subwoofer Feet

After unboxing your subwoofer, the next step is installing the feet. Due to the weight of our subwoofers, we recommend this step be completed by two people. Take your subwoofer out of the box, but leave the velvet and plastic bags on the subwoofer. You'll also notice a bag of metal spikes and rubber feet included in your packaging. If your subwoofer will be placed on carpet, use the metal carpet spikes as your footers. For surfaces other than carpet, such as wood, tile, certain tight weave rugs or vinyl, use the included metal disks under each of the spikes, or the rubber feet to prevent damage to the floor or floor covering.

To install the subwoofer spikes follow these steps:

1. With the velvet bag still covering the sub, gently roll it onto its top - exposing the 4 metal, round inserts on the bottom. Please be careful not to touch or otherwise damage the driver when your subwoofer is upside-down.

2. Gently screw each of the feet/carpet spikes into the threaded holes on the underside of the subwoofer. DO NOT force or cross-thread the spike. (See Figure A below.)

Note: If the sub is going to be placed on a surface that may be damaged by the carpet spikes, place one of the included metal disks under each spike, or use the included rubber feet.

3. After all four spikes have been installed, gently roll the subwoofer upright. If your sub is not sitting evenly on the floor, use the jam nuts on the spikes to level the subwoofer. (See Figure B below.)

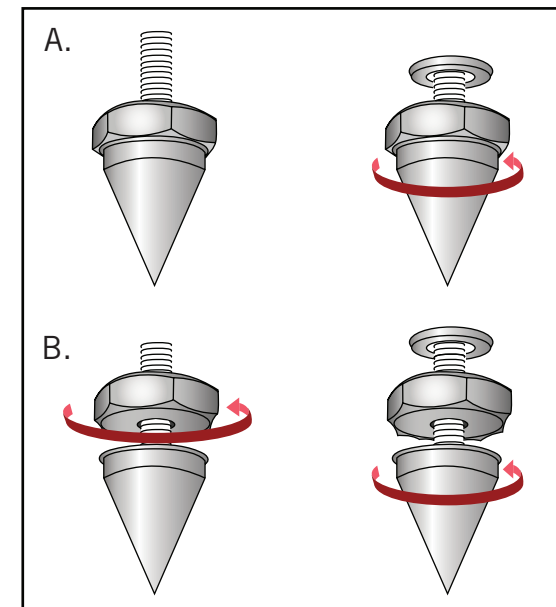

Placement

The location of your subwoofer will greatly affect how evenly the bass is distributed throughout the listening area. A subwoofer that's placed correctly will give you even, accurate sound throughout its frequency range.

Here are a few guidelines for getting the most out of your subwoofer:

1. The best way to place your subwoofer is to use the rule of 3rds or 5ths. To execute this, measure the width of the front or side wall of your theater. Then split that length into either 3 or 5 equal parts. Your sub can be placed centered between any two parts (see below).

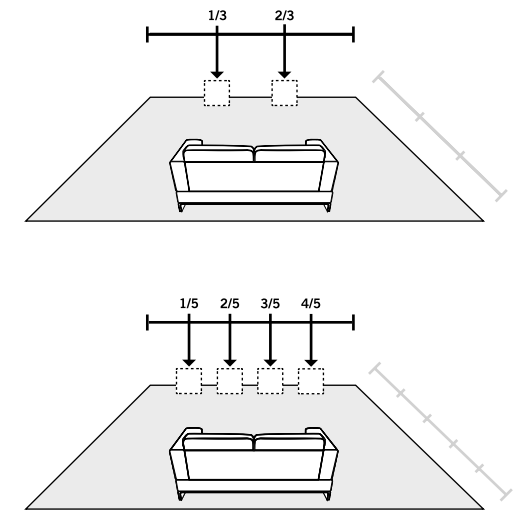

2. If your room doesn't allow for 3rds or 5ths placement, place your subwoofer near a corner to help eliminate uneven bass in the room. If you do place it in a corner, be sure it has at least 3 inches of clearance on all sides.

3. If a corner is impractical, the next best place is anywhere the room will allow. Your new sub has a wide range of adjustments you can make to fine tune its performance.

4. If you use more than one subwoofer, put them in asymmetric places relative to walls and open areas. Asymmetric placement is good for bass in that it can help create a grid of sound in your room. Again, 3rds or 5ths placement is best, then corners, then wherever it fits.