

# rotating av racks



**avrak** Inc.

[www.avrak.com](http://www.avrak.com)

# install with ease access



*Shipped fully assembled.*

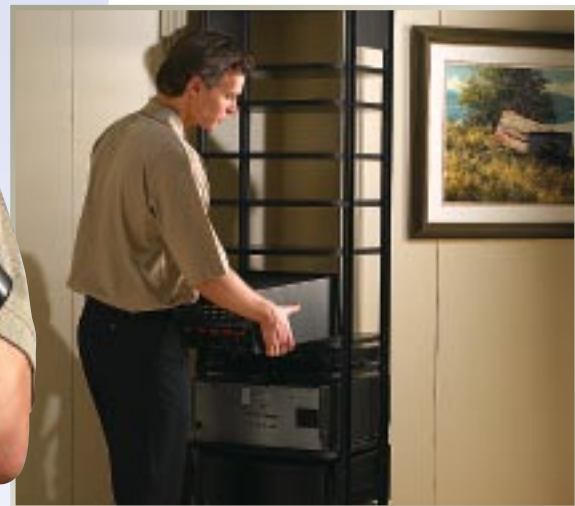

*Load equipment in minutes.*



*Installation and maintenance, now a breeze.*

# with ease



We know what it's like spending days, months or even years purchasing an audio/video system, then getting frustrated trying to cable it together without proper access to the back of your components. We've been there—it's where our idea of the rotating audio/video rack was born. Our racks rotate within an enclosure, pull out of an enclosure and then rotate, or rotate on a free-standing base providing complete access to the back.

Specifically engineered for home audio/video applications, we've made sure that your rack will perform flawlessly and make servicing your system a joy. Only the finest materials are used during manufacture such as black anodized angle aluminum for our vertical rails, 18 gauge steel brackets for our track systems, and a variety of fine hardwood veneers for the Avstånd and our premium line of Avfurnishings. To help you keep things organized, we provide velcro strips on every adjustable shelf to fasten wires and offer cable management kits for heavier cable. We also have built-in drawers that come in a standard or CD/DVD configuration with flat or contoured drawer fronts.

We set out to develop a better way of installing audio/video components. The result—a durable, precision manufactured, extremely functional, rotating AV rack, that we consider the best on the market and that will take the frustration out of your install.

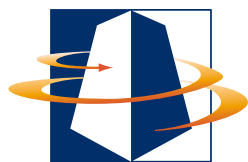

**av**rak Inc.

[www.avrak.com](http://www.avrak.com)



*Leading edge manufacturing  
technology delivers parts that are  
machined to exact tolerances.*



*Our racks are built to support  
the most demanding installation.*

# avräk



*Simply install the upper pivot pin, screw down the bottom pivot plate and slide the Avräk into the opening. You're now ready to adjust your shelves and insert components.*



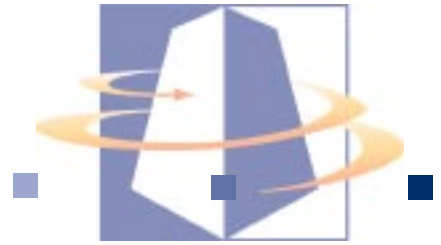

The cost effective, rotating audio/video rack solution—Avrāk rotates inside your cabinet or enclosure and mounts quickly with only eight screws.

The shelves are composed of durable black melamine composite panels, are infinitely adjustable, and are secured with four high-quality machine bolts threading into steel cross dowels. Velcro strips are mounted on the back of every adjustable shelf to assist in keeping wires organized. A wide rack option is also available for larger components.

Avrāk is shipped fully assembled with all required mounting hardware.

1 year parts warranty.

Wide rack option increases rack width from 18 1/2" to 19 1/2" inside width. When ordering the wide rack option for the Avrāk, the finished opening for the enclosure must be increased from 24" wide X 20" deep to 25 1/2" wide X 20 3/4" deep.

3/4" heavy duty shelf option increases shelf weight capacity from 75 lbs. to 150 lbs.



Rotates 360 degrees providing you with complete access to the back of your components.



Caster Base

### Caster Base

This option is for the Avrāk only and is meant for installations where a proper enclosure is not available. The base comes pre-mounted to your Avrāk.

Avrāk overall height will be increased by 1 3/4" when mounted on the caster base.

Avraks over 60" cannot be mounted on the caster base.

Maximum weight rating for the caster base is 350 lbs.

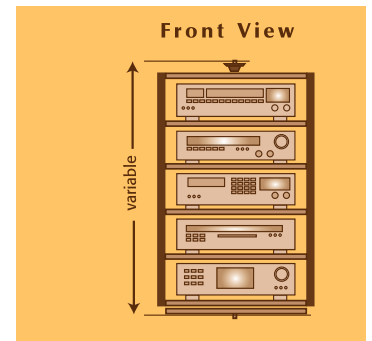
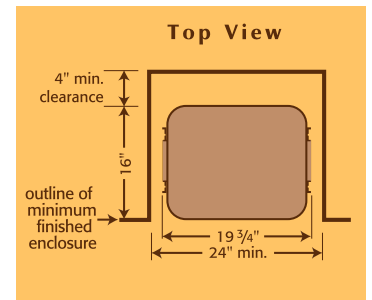
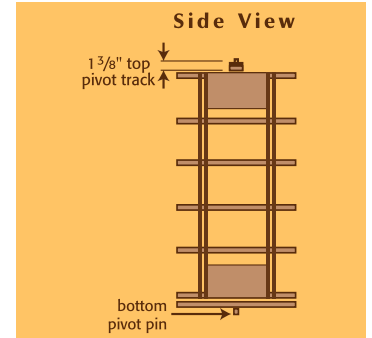

Unit Number	Minimum Finished Enclosure H X W X D	Maximum Component Clearance (MCC)	Adjustable Shelves*	Weight Rating
AV-72	72" X 24" X 20"	56 3/8" X 18 1/2" W	11	350 lbs.
AV-60	60" X 24" X 20"	46 3/8" X 18 1/2" W	9	350 lbs.
AV-48	48" X 24" X 20"	36 7/8" X 18 1/2" W	7	350 lbs.
AV-42	42" X 24" X 20"	32" X 18 1/2" W	6	350 lbs.
AV-36	36" X 24" X 20"	27 7/8" X 18 1/2" W	5	350 lbs.
AV-30	30" X 24" X 20"	22 1/4" X 18 1/2" W	4	350 lbs.

\*Bottom non-adjustable shelf included in shelf count. \*\*Optional 450 lbs. weight rating available. \*\*\*The top pivot pin must be mounted securely or the stability of the rack will be compromised.

- Maximum Component Clearance (MCC) is the total height of all your components.
- MCC calculated using 3/8" shelf and 1/2" air space.
- Standard rack/rail components will fit in Avrāk racks as the rails are recessed 1 1/2".
- Custom heights available up to 72".
- Specifications subject to change without notice.

**Note:** not all components may rotate inside a 24" enclosure. Please measure the components to be installed, diagonally and make the appropriate adjustments to the finished opening.

# avtræk



*Avtræk pulls out from the enclosure allowing it to be installed in a smaller opening than Avräk.*

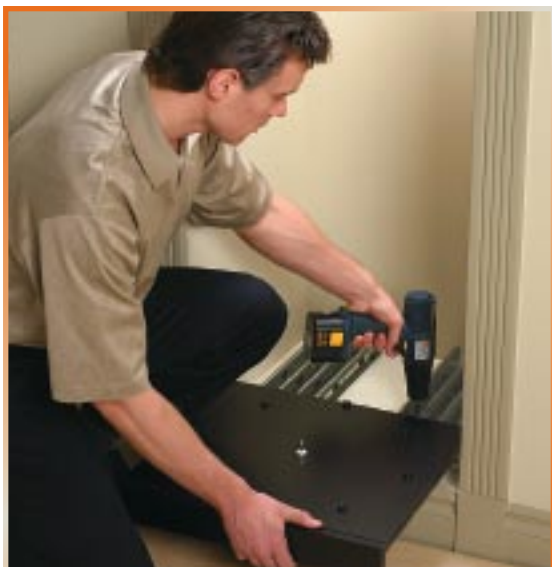

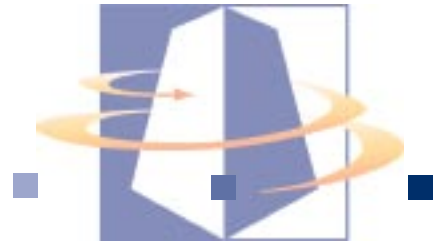

The Avträk is our rotating audio/video rack solution designed for installations where space is at a premium and fit is critical.

It is mounted on slides that attach to the top and bottom of your enclosure using industrial strength 18 gauge steel brackets. It pulls out 19" and then rotates 360 degrees for complete access to the back of your components.

Avträk comes complete with a front carriage cover plate for that clean look. Being constructed of the same material and with the same attention to detail as Avräk, Avträk will give you many years of trouble free operation. Velcro strips are mounted on the back of every adjustable shelf to assist in keeping wires organized.

Avträk is shipped fully assembled with all required mounting hardware.

1 year parts warranty.

Wide rack option increases rack width from 18 1/2" to 19 3/4" inside width. When ordering the wide rack option for the Avträk, the finished opening for the enclosure width must be increased from 20" wide X 18 5/8" deep to 21 1/8" wide X 18 5/8" deep.

3/4" heavy duty shelf option increases shelf weight capacity from 75 lbs. to 150 lbs.

### Keyed Carriage Lock

The Keyed Carriage Lock allows you to keep your Avträk locked down. This Avoption prevents your Avträk from being pulled out. Ideal for installations requiring minimal security.



AT-42

The cable management system shown above is available as a kit and listed in the Avoption section of this catalog.



Keyed Carriage Lock

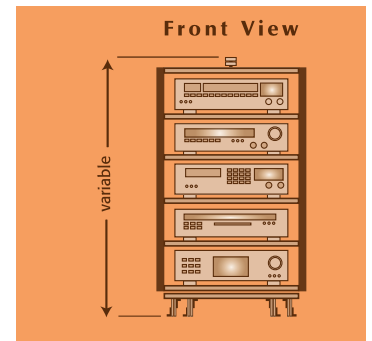
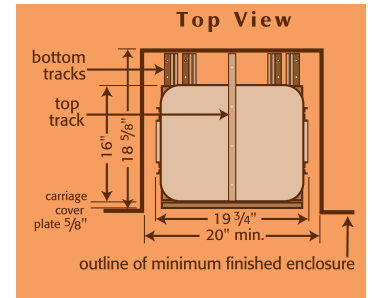
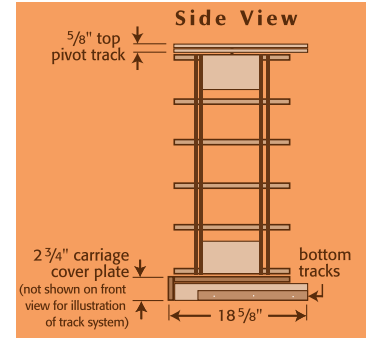

Unit Number	Minimum Finished Enclosure H X W X D	Maximum Component Clearance (MCC)	Adjustable Shelves*	Weight Rating
AT-72	72" X 20" X 18 5/8"	55 1/4" X 18 1/2" W	11	350 lbs.
AT-60	60" X 20" X 18 5/8"	45 1/2" X 18 1/2" W	9	350 lbs.
AT-48	48" X 20" X 18 5/8"	35 3/4" X 18 1/2" W	7	250 lbs.
AT-42	42" X 20" X 18 5/8"	30 7/8" X 18 1/2" W	6	250 lbs.
AT-36	36" X 20" X 18 5/8"	26" X 18 1/2" W	5	250 lbs.
AT-30	30" X 20" X 18 5/8"	21 1/8" X 18 1/2" W	4	150 lbs.

\*Bottom non-adjustable shelf included in shelf count. \*\*Optional 450 lbs. weight rating available. \*\*\*The top track must be mounted securely or the stability of the rack will be compromised.

- Maximum Component Clearance (MCC) is the total height of all your components.
- MCC calculated using 3/8" shelf and 1/2" air space.
- Standard rack/rail components will fit in Avräk racks as the rails are recessed 1 1/2".
- Custom heights available up to 72".
- Specifications subject to change without notice.

# AV Ständ



AS-54 / Cherry



AS-60, shown here  
without side panels.

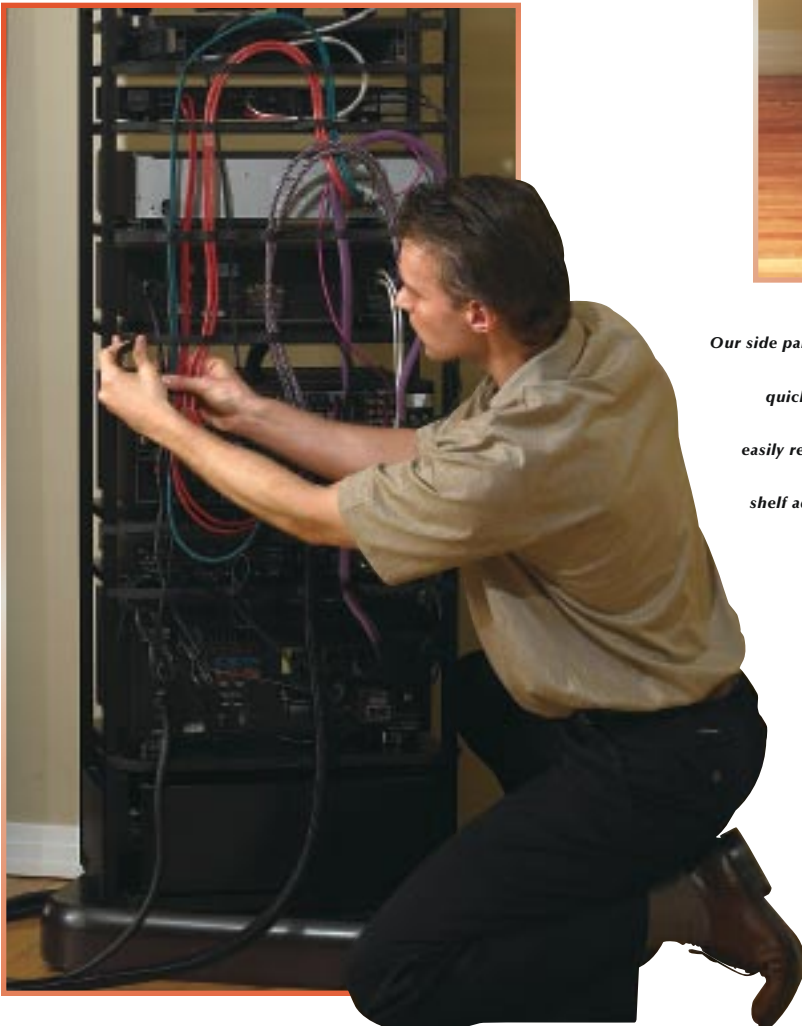

Our side panels install  
quickly and are  
easily removed for  
shelf adjustment.





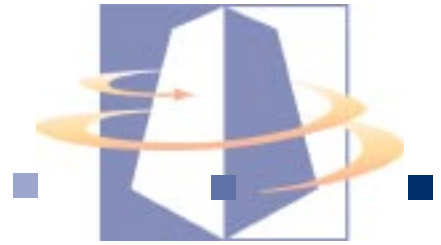

Hollow base may be filled for increased stability.



Textured Gloss Black Lacquer



Cherry



Maple



Red Mahogany

Our premium free-standing audio/video rack solution, Avstånd rotates 360 degrees on its own base for easy access to the back of your components.

Heavy duty levellers keep Avstånd and your components level while the hollow base may be filled with lead shot or sand for increased stability.

Avstånd side panels are available in a black textured lacquer, or finished in a variety of fine hardwood veneers shown to the left. They conveniently remove for easy shelf adjustment. The contoured top and base are finished in a textured gloss black lacquer, the top removes easily for ease of rotation in tight places.

Avstånd is available in 36" to 60" heights and is constructed of "best-of-breed" materials. Shelves are composed of durable black melamine composite panels, are infinitely adjustable, and are secured with four high-quality machine bolts threaded into steel cross dowels. Velcro strips are mounted on the back of every adjustable shelf to assist in keeping wires organized. A wide rack option is also available for larger components.

Avstånd ships fully assembled. One bolt attaches the rack to the base, providing for component placement minutes after removing Avstånd from the box.

1 year parts warranty.

Wide rack option increases rack width from 18 1/2" to 19 3/8" inside width.

3/4" heavy duty shelf option increases shelf weight capacity from 75 lbs. to 150 lbs.

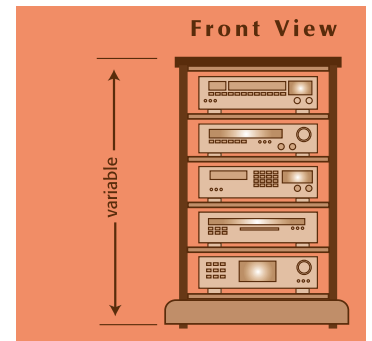
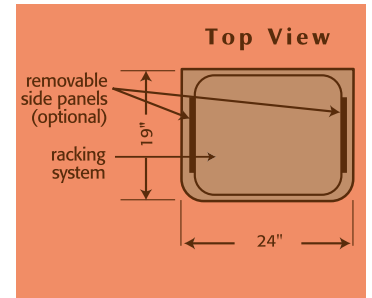
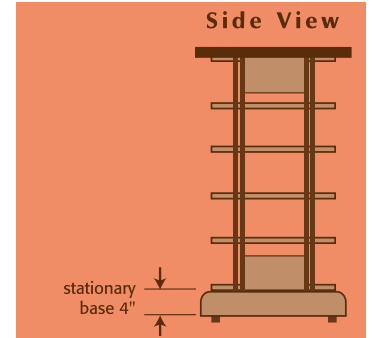

Unit Number	Unit Height & Base Size H X W X D	Maximum Component Clearance (MCC)	Adjustable Shelves*	Weight Rating
AS-60	60" X 24" X 19"	44 1/2" X 18 1/2" W	9	350 lbs.
AS-54	54" X 24" X 19"	39 5/8" X 18 1/2" W	8	350 lbs.
AS-48	48" X 24" X 19"	34 3/4" X 18 1/2" W	7	350 lbs.
AS-42	42" X 24" X 19"	29 7/8" X 18 1/2" W	6	350 lbs.
AS-36	36" X 24" X 19"	25" X 18 1/2" W	5	350 lbs.

\*Bottom non-adjustable shelf included in shelf count. \*\*Optional 450 lbs. weight rating is not available for the Avstånd. \*\*\*Large TV's or monitors are not to be placed on top of the Avstånd. \*\*\*\*Any heavy components must be placed in the lower half of the Avstånd.

- Regular and wide Avstånd have the same footprint.
- Custom heights up to 60" available.
- Specifications subject to change without notice.

# avfurnishings the plasma stand



*Plasma Stand Tall with optional wood doors finished with Cherry veneer shown to the right.*



*Plasma Stand Short shown here with Cherry veneer side panels.*



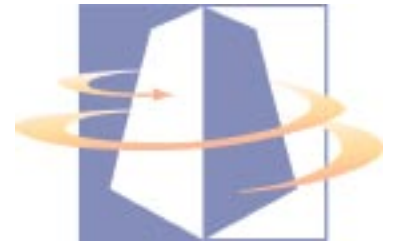

Cherry



Red Mahogany

Two racks rotate 360 degrees inside a free-standing enclosure for easy access to the backs of your components.

Contoured top and bottom with textured gloss black lacquer finish.

Standard height of 30" or 48" with a footprint of 60" wide X 22" deep.

Houses 2 Avraks with a MCC of 17 3/4" each for the Short or a MCC of 32 3/4" each for the Tall.

3 infinitely adjustable shelves per rack, 1 bottom fixed shelf per rack for the Short or 6 infinitely adjustable shelves per rack, 1 bottom fixed shelf per rack for the Tall.

4 - 6mm tempered black glass doors or wood doors finished in real Cherry or Red Mahogany wood veneers.

Side panels 3" thick for incredibly strong structural stability capable of supporting up to 200 lbs.

Sturdy engineering allows assembly with only 12 bolts threading into steel inserts for a strong positive union of cabinet components.

Constructed without a back to allow excessive heat build up to easily escape.

Side panels available in Cherry or Red Mahogany, finished with a clear gloss lacquer.

1 year parts warranty.

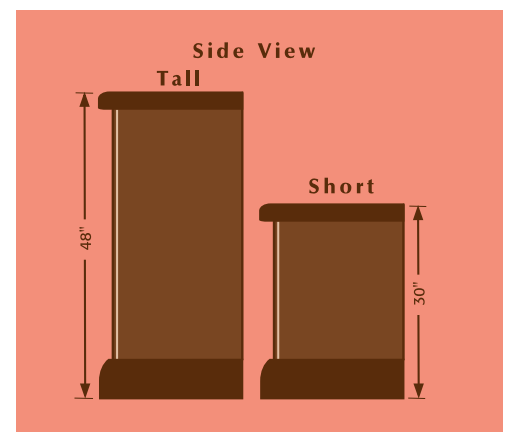
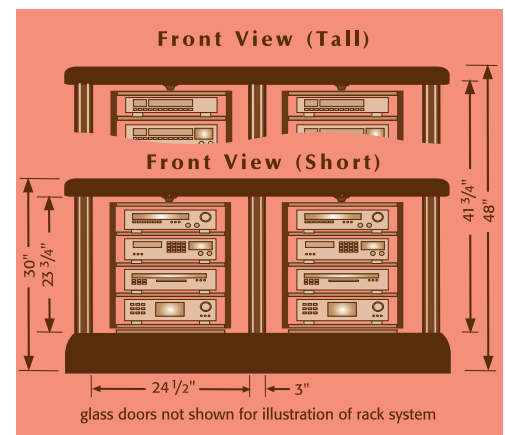
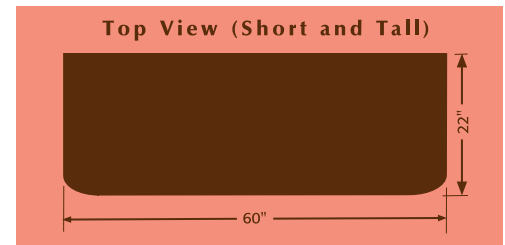

Unit Number	Unit Height & Base Size H X W X D	Maximum Component Clearance (MCC)	Adjustable Shelves*	Weight Rating**
AF-PSS	30" X 60" X 22"	2 racks with MCC 17 3/4" each	4/rack	350 lbs.
AF-PST	48" X 60" X 22"	2 racks with MCC 32 3/4" each	7/rack	350 lbs.

\*Bottom non-adjustable shelf included in shelf count.

\*\*Weight rating for each interior Avrak is 350 lbs. Weight rating of the top of the Plasma Stand is 200 lbs

- Rotational Component Clearance is 24 1/2". Measure the components corner to corner to confirm they can rotate within this measurement. Please allow extra clearance for any special cabling concerns.
- Specifications subject to change without notice.

*av* furnishings  
**the tower**



*Tower Tall shown above with Cherry veneer side panels and 6mm tempered black glass doors, Tower Short with optional wood doors finished with Cherry veneer shown to the right.*

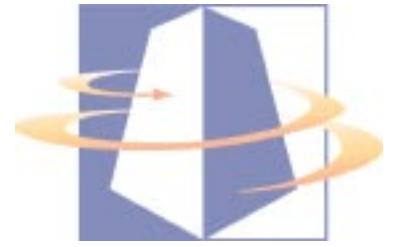

Assemble quickly with only 8 bolts  
threading into steel inserts.



Cherry



Red Mahogany

Rotates 360 degrees inside a free-standing enclosure for easy access to the backs of your components.

Contoured top and bottom with textured gloss black lacquer finish.

Standard height of 30" or 48" with footprint of 34" wide X 22" deep.

Houses 1 Avräk with a MCC of 17 3/4" for the Short or a MCC of 32 3/4" for the Tall.

3 infinitely adjustable shelves per rack, 1 bottom fixed shelf per rack for the Short or 6 infinitely adjustable shelves per rack, 1 bottom fixed shelf per rack for the Tall.

6mm tempered black glass doors or wood doors finished in real Cherry or Red Mahogany wood veneers.

Side panels 3" thick for incredibly strong structural stability capable of supporting up to 150 lbs.

Sturdy engineering allows assembly with only 8 bolts threading into steel inserts for a strong positive union of cabinet components.

Constructed without a back to allow excessive heat build up to easily escape.

Side panels available in Cherry or Red Mahogany, finished with a clear gloss lacquer.

1 year parts warranty.

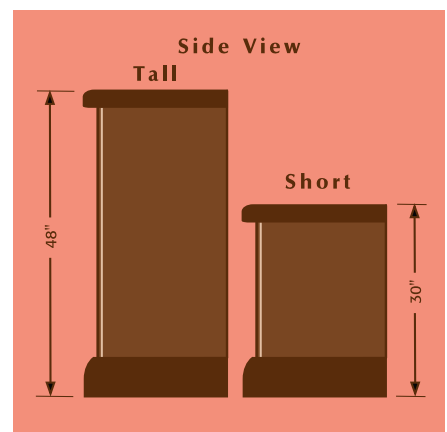
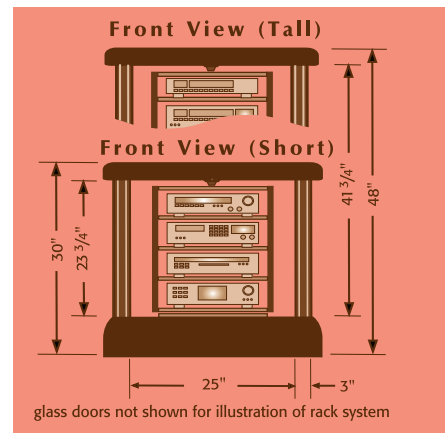
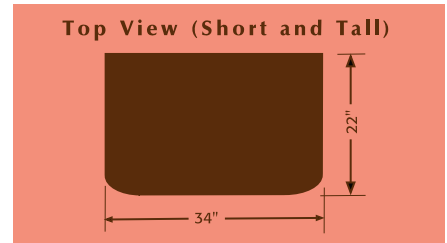

Unit Number	Unit Height & Base Size H X W X D	Maximum Component Clearance (MCC)	Adjustable Shelves*	Weight Rating**
AF-TS	30" X 34" X 22"	17 3/4"/rack	4/rack	350 lbs.
AF-TT	48" X 34" X 22"	32 3/4"/rack	7/rack	350 lbs.

\*Bottom non-adjustable shelf included in shelf count.

\*\*Weight rating for interior Avrak is 350 lbs. Weight rating of the top of the Tower is 150 lbs

- Rotational Component Clearance is 25". Measure the components corner to corner to confirm they can rotate within this measurement. Please allow extra clearance for any special cabling concerns.
- Specifications subject to change without notice.

## Avdråwer

This versatile drawer can be ordered in a standard or CD/DVD configuration. Standard configuration allows you to store a variety of items in one space (Fig. 2), while the CD/DVD configuration holds 96 CDs (Fig. 3) or 40 DVDs (not shown), or a combination of 32 CDs and 20 DVDs (Fig. 1). All configurations come with a flat drawer front (Fig. 2) that may be upgraded to a contoured front (Fig. 1 & 3). All Avdråwer configurations are available for the wide rack option.

*\*Contour front recommended for Avstånd  
Please deduct 7" from MCC for each drawer.*



## Deep Shelf

The deep shelf option increases the depth of our shelves from 16" to 18" with the extra 2" projecting out the back. Measuring the Deep Shelf diagonally, you will see that this option will require a larger finished enclosure.

*Weight rating for the deep shelf is 150 lbs.*

*"Minimum Finished Enclosure" size for the Avräk will need to be increased to 27" wide X 21 3/4" deep.*

*"Minimum Finished Enclosure" for a Wide Avräk must be at least 28 1/2" wide X 22 1/2" deep.*

*"Minimum Finished Enclosure" depth for the Avräk will need at least 20 3/8". This is to allow for wiring to clear the deep shelf. Also, when the Avräk is pulled out of the enclosure adjacent cabinet doors or walls must be at least 3 1/2" away from the side of the rack.*



*Diagonally measuring your components, much in the same manner as our installer pictured here is measuring the Deep Shelf, will give you the width required to rotate components within the finished enclosure for Avräk installations.*

# tions



## **Cable Management**

### *AV Wire Kit*

The ideal way to protect and organize cables coming from external components and input sources. When used in conjunction with the standard velcro strips attached to the back of every adjustable shelf, the kit completes an effective cable and wire management system. The kit comes complete with 20' of 1 1/4" conduit, 10' of 3/4" conduit, 3 velcro conduit straps and 20 wire ties.



AV-Wire Kit

### *Conduit, Straps and Ties*

Both 1 1/4" and 3/4" conduit may be purchased separately. In addition, we offer wire ties in 100 count bags and conduit straps in 10 count bags.



Deep Shelf

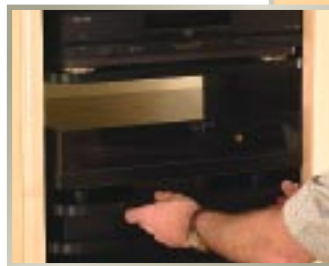

## **T-table**

Our turn table pull out shelf is 18" W x 16" D x 2 1/2" H. The shelf pulls out 15" on metal slides and will support 60 lbs. Also available for wide rack.

*\*Please note that 2 1/2" must be subtracted from the MCC for this option.*

*With the Deep Shelf  
larger components have  
the support they require.*





**avrak** Inc.

St. Albert, Alberta, Canada  
Toll free fax: 1-888-973-3500  
Phone: 1-780-418-1528  
email: [info@avrak.com](mailto:info@avrak.com)

*Distributed by:*

[www.avrak.com](http://www.avrak.com)