

MODEL L-23

FOR UP TO 32" TV

- Lift Extends 23" Upwards
- TV Maximum Screen Size: 32"
- TV Maximum Height: 22"
- Maximum Weight: 130 lbs.

Compact and quiet, Model L-23 is the perfect choice to conceal small screens and monitors. With slim dimensions and easy adjustability, this lift is used in homes, classrooms and luxury vehicles around the world. It includes a wireless remote, wired backup controls and optional smart home integration kit providing limitless flexibility for installation and control.

- Slim Design
- Universal Mounting Patterns
- Near Silent Operation
- Popular for Desks, Kitchen Islands, Bathrooms and Moving Vehicles



All Nexus products are shipped in custom-made protective packaging, and they include everything you need to mount and operate them. The products are designed for easy assembly and simple instructions with photos are included.

MODEL L-23

TECHNICAL SPECIFICATIONS

- 130 lbs. total lift capacity
- TV maximum screen size: 32"
- Travels 23"
- No exposed tracks, gears or scissors
- Accommodates standard VESA mounts: 75mm x 75mm, 100mm x 100mm, 200mm x 100mm, 200mm x 200mm
- Optional TV mount sizes are VESA standard 300mm x 300mm or 400mm x 200mm
- UL recognized
- Draws 3.5 Amps @ 110V and 1.75 Amps @ 220V at max thrust
- Speed 1.7" per sec. (only 13 sec. to fully raise)
- Quiet - runs at just 45 dB
- Chain-driven mechanism
- Steel construction
- Your choice of RF remote or Control System Integration Kit (CSI Kit includes IR remote and contact closure interface)
- Exclusive Nexus 21 safety features included
- "Soft Start" and "Soft Stop" for smooth ride
- Power is Available in These Formats:
USA, 110V / Europe, 230V / Japan, 100V
Australia, 240V / UK, 230V

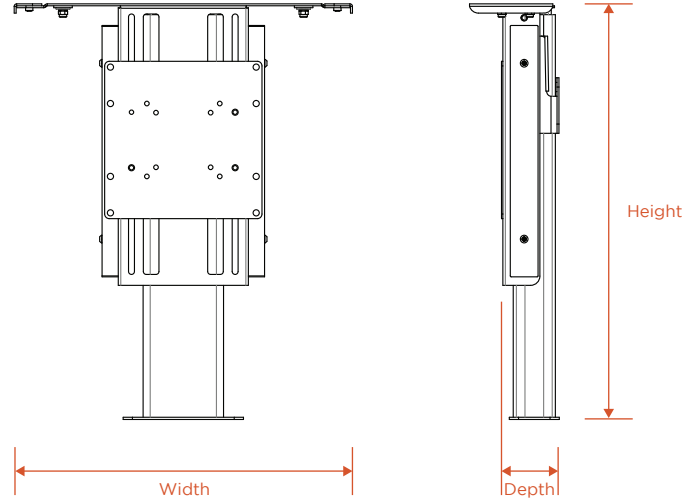

Height: 22.5"
Width: 18.3"
Depth: 3.1" from back wall to rear of TV

WHAT'S IN THE BOX

- Motorized lift column (the motorized unit is pre-assembled and ready to use)
- Heavy duty monitor hanger with universal mounting pattern
- Top plate with finger safety
- Base plate and upper back mounting bracket
- Control box with power cord
- Remote control and receiver (your choice of RF or CSI Kit*)
- Backup control switch
- Cord control wrap
- All hardware for assembly and mounting
- Full assembly instructions with photos



CONTROL OPTIONS

Your choice of RF remote or Control System Integration Kit (CSI Kit*). Wired button pad included with both.



*CSI Kit includes IR remote and contact closure interface

COMPATIBLE LID STYLES

Mounting bracket for floating lid included (our standard option) or purchase guides for a hinged lid version. Built-in finger safety system included.

