



MODEL L-27

FOR UP TO 48" TV

- Lift Extends 26.5" Upwards
- TV Maximum Screen Size: 48"
- TV Maximum Height: 25.5"
- Maximum Weight: 130 lbs.

Model L-27 packs an incredible combination of features into a compact and powerful system. Smooth motion, quiet operation and industry-leading reliability have made this lift the choice of homeowners and professionals around the world. Popular uses include concealing your TV at the foot of the bed, behind electric fireplaces, and in watercraft and custom coaches.

- Lowest Profile of any Lift
- Near Silent Operation
- Remote Control Included
- Popular for Foot of Bed, Boats and RV Applications



All Nexus products are shipped in custom-made protective packaging, and they include everything you need to mount and operate them. The products are designed for easy assembly and simple instructions with photos are included.

MODEL L-27

TECHNICAL SPECIFICATIONS

- 130 lbs. total lift capacity
- TV maximum screen size: 48"
- Travels 26.5"
- No exposed tracks, gears or scissors
- UL recognized
- Draws 3.5 Amps @ 110V and 1.75 Amps @ 220V at max thrust
- Speed 1.7" / sec. (only 15 sec. to fully raise)
- Quiet - runs at just 45 dB
- Chain-driven mechanism
- Steel construction
- Your choice of RF remote or Control System Integration Kit (CSI Kit includes IR remote and contact closure interface)
- Exclusive Nexus 21 safety features included
- "Soft Start" and "Soft Stop" for smooth ride
- Power is Available in These Formats:
USA, 110V / Europe, 230V / Japan, 100V
Australia, 240V / UK, 230V

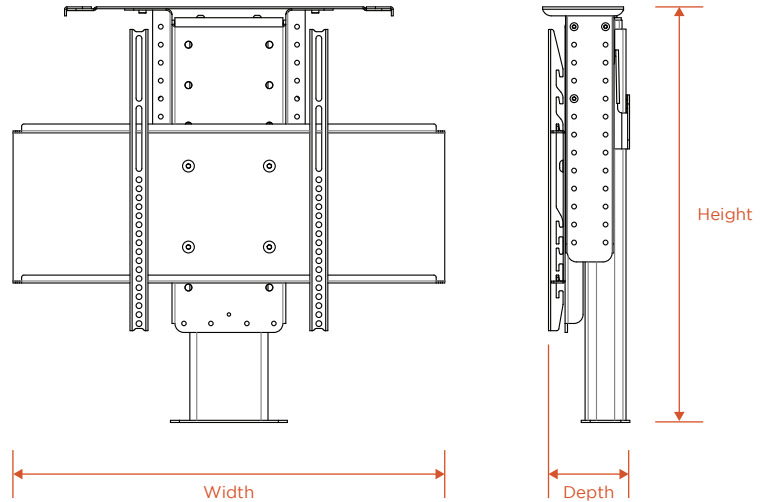

Height: 23.2" Min / 31.2" Max
Width: 24"
Depth: 4.5" from back wall to rear of TV

WHAT'S IN THE BOX

- Motorized lift column (the motorized unit is pre-assembled and ready to use)
- Heavy duty screen support with universal TV mounting plate
- Height adjustable top supports
- Top plate with adjustable extensions and finger safety
- Upper and lower back mounting brackets
- Control box with power cord
- Remote control and receiver (your choice of RF or CSI Kit*)
- Backup control switch
- Cord control wrap
- All hardware for assembly and mounting
- Full assembly instructions with photos



CONTROL OPTIONS

Your choice of RF remote or Control System Integration Kit (CSI Kit*). Wired button pad included with both.



*CSI Kit includes IR remote and contact closure interface

COMPATIBLE LID STYLES

Mounting bracket for floating lid included (our standard option) or purchase guides for a hinged lid version. Built-in finger safety system included.

